

Model 55HD

(Shown below)

Includes Basin Filter Model B6Ps

Model 75HD

Includes Basin Filter Model B6Ps



Model 55HD

Do Not Exceed Rated oil Capacity of 45 lbs (6.5 gallons)

Model 75HD

Do Not Exceed Rated oil Capacity of 80 lbs (11 gallons)



GGB VENTURES INTERNATIONAL INC.
'Over 65 years of experience'

INTERNATIONAL IMPORTER / EXPORTER

31-910 ROWNTREE DAIRY ROAD
VAUGHAN, ONTARIO, CANADA, L4L 5W6

TOLL FREE: 1 866 761 1080 TOLL FAX: 866 761 1077 ggbventures.com

MIROIL Division of Oil Process Systems Inc.

602 North Tacoma Street Allentown, Pennsylvania 18109

PHONE: 610 437-4618 FAX: 610 437-3377 E-mail: info@miroil.com Web: www.miroil.com

"Heads Above the Rest"

30 Years
1973 - 2003

Dear Customer:

Congratulations on your selection of our High Performance Power Filter Machine which continues over 30 years of leadership in oil management.

Your Filter Machine is an important tool for fryer oil management. It is designed to achieve maximum performance for removal of fine crumb and food materials at the lowest cost.

Another important part of oil management is **fryliquid™ antioxidant**. When you use this product with your filter machine you will experience enhanced oil performance and enhanced food quality. This combination delivers benefits not available from other filter machines.

- Provides consistent and enhanced food quality
- Oil savings from 25% to 40%
- Fryers stay free of carbon and gum deposits
- The MirOil filter does not leach harmful chemicals like paper filters
- Faster set-up and clean-up will save on labor
- Throw-away paper filters, D. E. powder or expensive cartridges are not needed.
- MirOil "Rinse & Reuse" filter bags clean up in seconds under hot water spray.

Why fryliquid™ antioxidant and your filter machine deliver these benefits.

All oil breakdown substances are liquid. They pass through filters and filter aids and remain in the oil. As they accumulate, they undermine the nutritional profile and the cooking performance of the oil. **fryliquid™ antioxidant** prevents these breakdown liquid substances from forming in the oil.

This is why **fryliquid™ antioxidant** is able to provide total control of food quality and oil performance. **fryliquid™ antioxidant** prevents off flavors and odors. **fryliquid™ antioxidant does not react** with the oil or with the food.

To receive the full benefit from your MirOil Filter Machine, just follow these simple rules.

1. Set up a regular schedule to filter once a day.
2. Add **fryliquid™ antioxidant** to your oil before each meal session.
3. Follow the filtering and freshening procedures outlined in this manual.

For questions about **fryliquid™ antioxidant** or your **Power Filter Machine** . . .

Frying Hot Line 866.761.1080

Additional Tips

Order a spare filter bag so you are prepared if it may be required in the future.

If the oil for discard is held overnight in the kitchen for security reasons or if you need a measure for the freshening oil Order a Model 30LG utility pail - for measuring and / or storing up to 5 gallons of oil.

**** DO NOT ** pump water through the pump.
This will rust the components and the pump will not turn!**



GGB VENTURES INTERNATIONAL INC.
'Over 65 years of experience'

INTERNATIONAL IMPORTER / EXPORTER
31-910 ROWNTREE DAIRY ROAD
VAUGHAN, ONTARIO, CANADA, L4L 5W6
TOLL FREE: 1 866 761 1080 TOLL FAX: 866 761 1077 ggbventures.com

Loss or Damage During Shipment

Inspect all cartons for damage before unpacking. Your MirOil pump was thoroughly inspected before leaving our factory. The carrier is responsible for safe delivery. All claims for any loss or damage in transit must be made to the carrier. MirOil will assist with claims **IF** damage has been promptly reported to the carrier.

1 Year Limited Warranty on your Filter Machine

This product is warranted only against defects in workmanship or materials for 1 year from date of the filter machine is placed in service or not longer than 15 months from date of purchase. Liability under the basic 1 year limited warranty is limited to replacing or repairing parts FOB Allentown PA. Parts must be returned to our factory with shipping costs prepaid.

The 1 year warranty does not cover the costs of service labor or shipping to replace parts.

The use of the filter pump for pumping any liquid other than fryer oil will contaminate the pump and piping. This will contaminate the oil and may void this warranty

Important Limits for Coverage Under All Warranties

No warranty described above covers the replacement of parts that become inoperative because of wear (except filter bags) or abuse or for parts subjected to abuse/misuse, negligence, accident or if the product has been improperly repaired or altered by user or a 3rd party. No other warranty, expressed or implied, is authorized to be made by any parties on behalf of MirOil.

The manufacturer and the manufacturer's sales agents and/or agencies accept no liability for the use or misuse of this machine. Expressly excluded from warranty are implied warranties of merchantability and fitness for purpose. Manufacturer, agents and sales agencies disclaim all liability for accidents resulting from use or the misuse of this equipment.

Call for warranty information in Canada 1. 866.761.1080

Priming for Hand Operated Pumps

An oil film is needed as a seal between the internal parts to prime the pump. During storage and shipping the oil may degrade and become ineffective as a seal. If there is no pumping, disconnect the discharge hose assembly at the quick coupler and pour a quarter cup of oil into the top of the pump through the hose connection. CAUTION: After adding oil, reconnect the hose coupler carefully. Before turning the pump handle, make sure the nozzle is aimed at the fryer or it is installed into the nozzle holder. Use this procedure when the pump does not prime because it has not been used for an extended period.

If your oil / fat is solid at room temperature:

If a plug of solid fat or shortening forms in the hose, it will prevent pumping.

Procedure to prevent plug of solid oil, fat or shortening:

The oil film on the inside wall may collect at a loop in the hose and form a plug of solid fat. This will prevent the pump from priming. After filtering, disconnect the discharge hose and hang it from a hook to drain. Use a small collector pan or place hose nozzle in holder tube on Mobility Basin to avoid oil dripping on the floor.

Procedure for correcting blockage from plug of solid fat:

Try to pour some water through the discharge hose. If the water will not pass through the hose it is blocked with fat. Melt the fat plug by placing the hose in a large tub or sink with hot water.

**** DO NOT ** pump water through the pump.**

This will rust the components and the pump will not turn!

Safety Caution:

Residue of water in the hose can cause a dangerous splatter of hot oil.

After the fat plug is melted, make sure the water is fully drained before the hose is recoupled. Before turning ON the power filter always make sure the discharge hose nozzle is directed at the fryer. If the pump is still not primed, allow the pump to run for about 3 to 5 minutes so the pump heat may melt any residue of fat in or near the pump body.

Safety first - Make sure the hose nozzle is in the holder tube on the Pump Module when the pump is running.



GGB VENTURES INTERNATIONAL INC.
'Over 65 years of experience'

INTERNATIONAL IMPORTER / EXPORTER

31-910 ROWNTREE DAIRY ROAD
VAUGHAN, ONTARIO, CANADA, L4L 5W6

TOLL FREE: 1 866 761 1080 TOLL FAX: 866 761 1077 ggbventures.com

The following parts are included for assembly
Carton #1 for Model 55 & 75HD

Assembly of Hot Oil Pump
Mounted on Handle



Use safety strap to keep the lever arms in locked position. (b&c)
Pull on coupler to insure proper attachment.

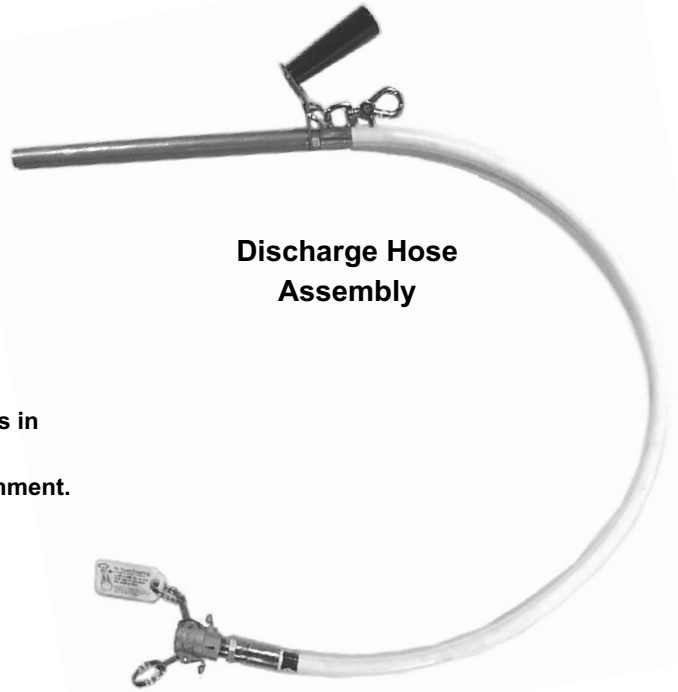

Discharge Hose
Assembly

The following parts are included for assembly
Carton #2 for Model 55 & 75HD

Models 55 & 75HD

Includes Model B6P Filter Assembly
for drain operation



*fryliquid*TM



Trolley



Assembly of Models 55 & 75 HD

Step 1.
Slide pump/handle assembly into receiver tubes in basin



Step 2.
Insert tube at end of hose (from hot oil pump suction) into the socket on the side of the Filter Basin until the tube is fully seated.

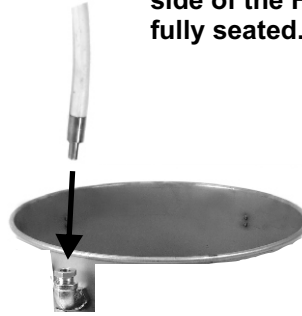

Step 3.
Remove pin, turn & remount crank handle from shipping position to the correct position for pumping. Reinstall pin.



Step 4.
Carefully attach the quick coupling on the end of the Discharge Hose to the mating fitting on the pump/handle assembly

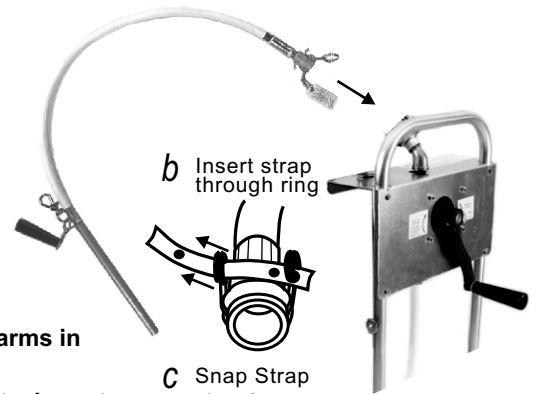

Use safety strap to keep the lever arms in locked position. (b&c)
Pull on coupler to insure proper attachment.

The Filter Machine is ready for use.
Be sure to read the instructions before placing machine into service.

**Assembled
Model 55HD**



GGB VENTURES INTERNATIONAL INC.
'Over 65 years of experience'

INTERNATIONAL IMPORTER / EXPORTER

31-910 ROWNTREE DAIRY ROAD
VAUGHAN, ONTARIO, CANADA, L4L 5W6

TOLL FREE: 1 866 761 1080 TOLL FAX: 866 761 1077 ggbventures.com

Filter Procedure for Model HD for use with fryers with drain valves.

CAUTION: Couple the hose. Pull hard on the hose to make sure the lever arms are locked.
Make sure hose nozzle is in the nozzle holder tube on the pump.

Filter oil at temperatures from 300°F (148°C) to 350°F (176°C)

- Step 1-** Lock wheel stabilizer into place. (See fig. 1) The current pump system has a handle brake instead of black knob shown below
- Step 2-** Place EZ Flow™ Filter across the Basin.
Carefully open the fryer valve to drain oil into the filter basin through the filter bag.
- Step 3-** Close the drain valve turn pump to return the oil back to the fryer
- Step 4-** Discard heavy crumb load before filtering the next fryer. Use a bus tray or carton to allow the crumb to cool because hot crumb will melt plastic garbage can liners.

Clean your filter under hot water spray. Store the filter in the filter basin to avoid accidental damage.

Do not wash the filter in a dishwasher or use soap. The least residue of soap is harmful to the oil.

If solid oil or shortening is used, before storing the filter machine, turn the pump handle clockwise to empty the oil from the pump cavity.

Uncouple the hose and store it in a hanging position to prevent a fat plug from forming when it collects and solidifies at a loop or bend of the hose.

More notes for great fried food:

1. Add *fryliquid*™ antioxidant to your oil after filtering and/or before each meal session. This will capture oil breakdown substances as they form in the oil and prevent oil breakdown reactions.
2. Filter once a day when *fryliquid*™ antioxidant is used unless crumb load is extremely heavy.
3. Follow the filtering and freshening procedures described in your brochure for *fryliquid*™ antioxidant and the New Frying Technology to choose an oil management program for your fry station.

For assistance call . . . 866.761.1080

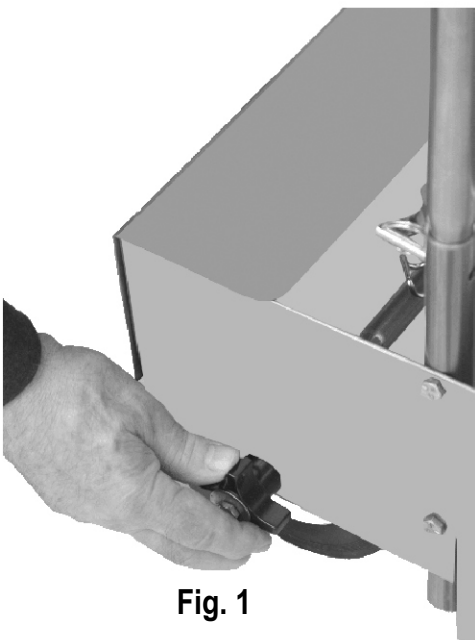
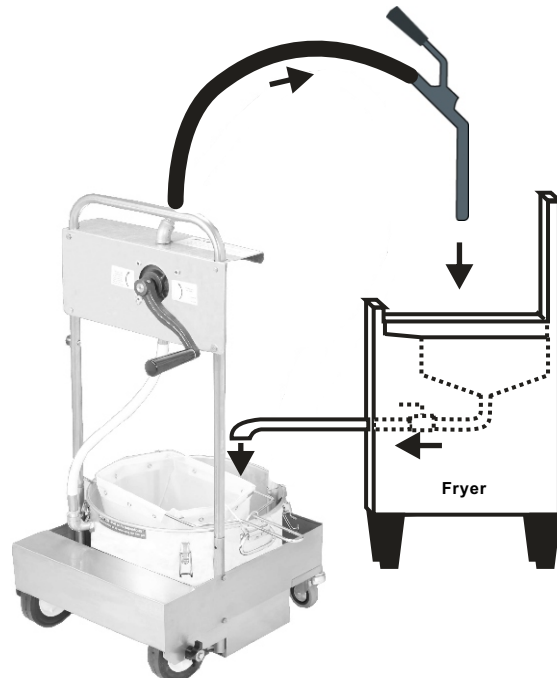

Fig. 1



GGB VENTURES INTERNATIONAL INC.
"Over 65 years of experience"

INTERNATIONAL IMPORTER / EXPORTER

31-910 ROWNTREE DAIRY ROAD
VAUGHAN, ONTARIO, CANADA, L4L 5W6

TOLL FREE: 1 866 761 1080 TOLL FAX: 866 761 1077 ggbventures.com

SERIAL #'S: 20501 TO PRESENT

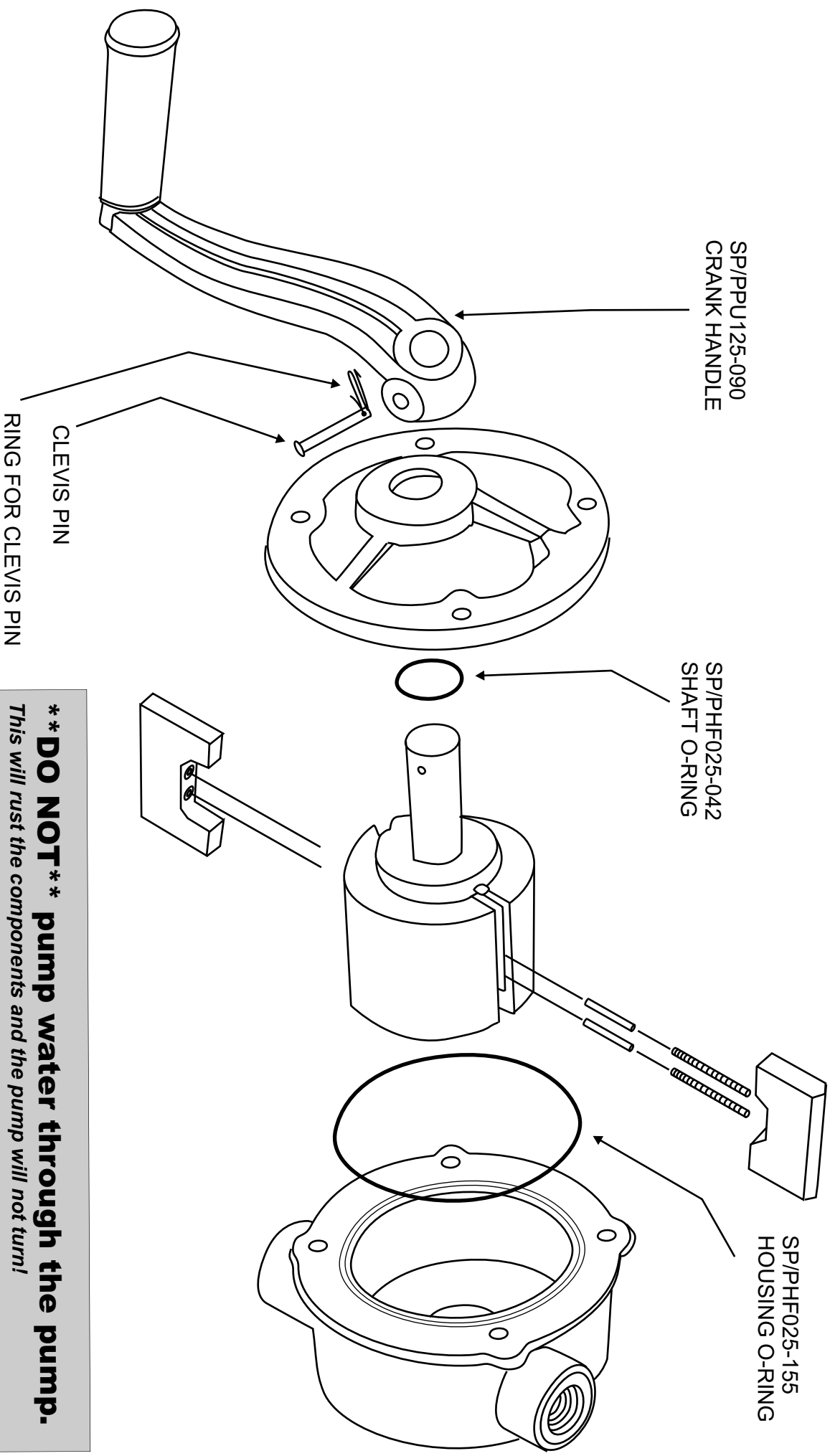

**** DO NOT ** pump water through the pump.**
This will rust the components and the pump will not turn!

1 Year Limited Warranty on your Filter Machine

This product is warranted only against defects in workmanship or materials for 1 year from date of the filter machine is placed in service or not longer than 15 months from date of purchase. Liability under the basic 1 year limited warranty is limited to replacing or repairing parts. Parts must be returned to GGB Ventures INT'L, Inc. or its service agencies with shipping costs prepaid. The 1 year warranty does not cover the costs of service labor or shipping to replace parts.

The use of the filter pump for pumping any liquid other than fryer oil will contaminate the pump and piping. This will contaminate the oil and may void this warranty

Important Limits for Coverage Under All Warranties

No warranty described above covers the replacement of parts that become inoperative because of wear or abuse or for parts subjected to abuse/misuse, negligence, accident or if the product has been improperly repaired or altered by user or a 3rd party. No other warranty, expressed or implied, is authorized to be made by any parties on behalf of the manufacturer of GGB Ventures INT'L, Inc.

The manufacturer and the manufacturer's sales agents and/or agencies accept no liability for the use or misuse of this machine. Expressly excluded from warranty are implied warranties of merchantability and fitness for purpose. Manufacturer, agents and sales agencies disclaim all liability for accidents resulting from use or the misuse of this equipment.

Call for warranty information in Canada 1.866.761.1080

.....
Cut and fax / send lower portion



Cut and fax / send lower portion



Cut and fax / send lower portion

Avoid losing protection under the Warranty

FAX this Warranty Registration promptly to (866) 761 1077

or . . . add postage and mail to

GGB VENTURES INT'L, INC.



GGB VENTURES INTERNATIONAL INC.
"Over 65 years of experience"

INTERNATIONAL IMPORTER / EXPORTER
31-910 ROWNTREE DAIRY ROAD
VAUGHAN, ONTARIO, CANADA, L4L 5W6
TOLL FREE: 1 866 761 1080 TOLL FAX: 866 761 1077 ggbventures.com

Filter Machine Model No. _____

Serial No. _____

Oil Pump Model No. _____

Serial No. _____

Filter Bag Model No. _____

Serial No. _____

Owner _____

Contact Person _____

Purchased From _____

Date purchased _____

Date placed in service _____